

**⚡ Rugged, Reliable, Versatile...
...Built to Last!**



MultiCam's 5000 Series CNC routers are our most flexible machines. Designed for high-speed routing in a broad range of woodworking, plastic and non-ferrous metal applications, the 5000 Series is easily configured to meet most application requirements. Rigid all-steel construction and space saving, moving-gantry design makes the 5000 Series a robust, commercial-grade machine designed for heavy-duty CNC routing. With the industry's largest range of standard table sizes and spindle configurations, Multicam's 5000 Series CNC routers are an ideal choice in today's competitive manufacturing environment.

MultiCam[®]
CNC Cutting Solutions

1025 West Royal Ln. DFW Airport, TX 75261 • PO Box 612048 Dallas, TX 75261 • 972.929.4070
fax 972.929.4071 • email sales@multicam.com • www.multicam.com

5000 Series Specifications

No machine offers more standard features than the MultiCam.

- Automatic Tool Calibration
- User-friendly operator interface
- 25mm linear ball bearing profile rails for maximum stiffness
- 2,200 inches/minute rapid traverse
- Standard Automatic Tool Calibration.
- High Speed 3-axis Motion Controller
- 12 Megabytes of Memory with unlimited file size transfer capabilities
- 2 phase digital brushless, synchronous electric motors are standard or brushless AC servo system is optional
- Standard Ethernet or RS232 direct connections



ATC (Automatic Tool Changer)

The 5000 series machine is available with an optional 12-position rotary tool changer. The system is optimized for bidirectional rotation and takes the shortest route to help reduce tool change time. All ATC systems come standard with Automatic Tool Calibration, and the tool change routines are built into the controls simplifying integration to your favorite CAM software. An Automatic Tool Changer solution will help reduce job times, improve accuracy, and reduce setup errors.



Standard Working Surface

The standard working surface is a 1" thick 80 - 82 Durometer phenolic with a grid pattern to utilize 0.500 x 0.250 foam gasket tape. The phenolic is mounted to the top of the steel base frame and is machined in place. This ensures a flat cutting surface normal to the spindle. Phenolic makes an excellent work surface because of its dependable mechanical strength and dimensional stability. In addition phenolic has a low moisture absorption, resists heat and wear, and can be repaired as needed.



5000 Series Specifications

Base Frame

The MultiCam 5000 Series base frame is a one-piece steel plate frame that is welded, stress-relieved, and precision-machined. One-piece construction allows for a very accurate and smooth cutting system, while greatly reducing the amount of time needed for installation and essentially removing the possibility for installation errors that could affect the performance and accuracy of the system.

Dual X-axis – 25mm Linear Rails, AC Brushless Servos, Precision Planetary Gearboxes, and Rack and Pinion

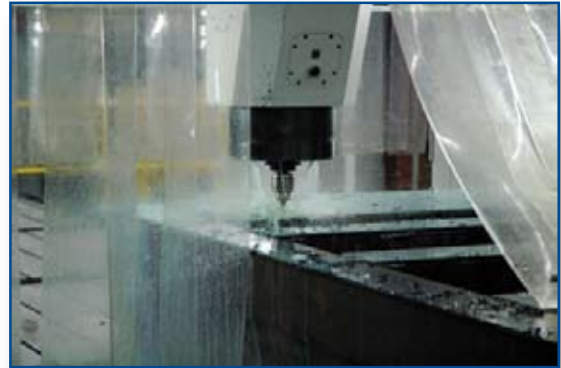

Gantry

The gantry is made of an 8" x 12" steel tube with internal stiffeners and is welded, stress-relieved, and precision-machined. The gantry has been engineered to provide a smooth, vibration free cut.

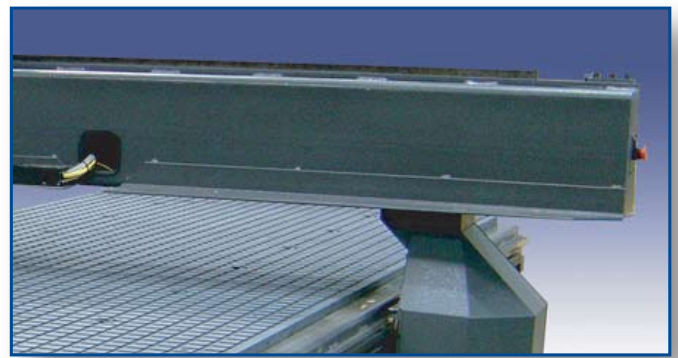

Gantry Supports

The 5000 Series gantry supports are manufactured from grey iron castings. These cast iron components, in conjunction with wide X-axis bearing spacing, help dampen vibration and give the structural tube gantry extremely rigid support.



Linear Bearings

The 25mm ball linear bearing profile rails with stainless spring steel strip cover

- High rigidity and top load capacities in all load directions
- Lowest possible noise level and best running characteristics
- High torque load capacity
- 4 bearing packs per axis
- 30,400 Nm or 22,421 lb-ft dynamic capacity per pack



5000 Series Specifications

Precision Planetary Gearboxes

Alpha Precision Planetary Gearboxes are the top of the line in the industry. Case hardened and finished ground high carbon alloy steel gears guarantee the lowest backlash and highest service life available. Alpha Gearboxes are one of the many components that make the MultiCam a smooth, accurate, and long-lasting cutting system.

- Single Stage 10:1
- Backlash < 2 arcmin
- Efficiency > 97%
- Low noise level
- Integrated thermal length compensation
- Designed for cyclic and continuous operation
- 5-Year Manufacturer Warranty

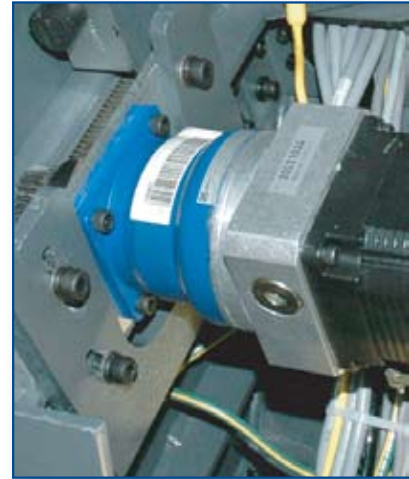

Regulator Units

Machines equipped with tool changing spindles come standard with SMC filter regulator units that also include an ambient air drier.



Ball Screw Assembly

The 5000 Series ball screw assembly has an available 18" of stroke that is ideal when using specialty tools and allows for the option of adding larger gantry clearance in the field. Gantry riser blocks are available to increase the throat of the machine by 4" or 8". The 16mm ball screw is supported by precision dual angular contact ball bearings in a steel housing. The top of the screw is mounted to a spring-actuated failsafe brake system.

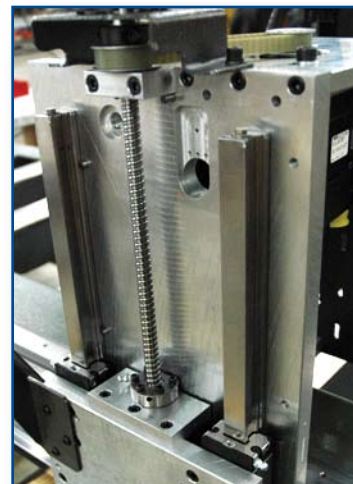

5000 Series Specifications

Digital Servo Drives

Teknic's SSt digital servo drives are high-bandwidth, digital vector servo drive systems and are standard on all 5000 Series machines. These drives seamlessly integrate position, velocity, and torque loops to provide uncompromised tracking accuracy, smoothness and reliability. The SSt drives used in MultiCam servo-driven machines are the latest in a line of high-performance drives that advances the state of the art by utilizing this seamless coordination in such a way to allow all information to be shared in real time so all system functions cooperate in any situation. For example, if the torque loop senses that the motor has reached 100% torque output, it is instantly passed upstream to the servo compensator and the system delivers a coordinated response, maintaining elegant control. You will realize tighter tracking, smoother motion, and faster rapid traverse - all of which yield superior machine throughput and reliability.



Servo Drive Features:

- SSt-1500 is 23A peak, 10 continuous @ 75Vdc
- Digital control loops with 800Hz large signal velocity bandwidth
- 2kHz small signal response
- 35 microsecond total servo phase delay. The SSt is the fastest in the industry
- True, closed-loop, sinewave commutation with vector feed-forward and DQ decoupling provides near-zero torque response time at any speed. This maximizes motor responsiveness and minimizes motor heating
- The SSt utilizes an adaptive control algorithm (IMT) based on Neural Fuzzy Logic. The IMT virtually eliminates the concern of inertia matching and allows for loads of large and varying inertia without impacting performance.
- The SSt uses small-signal, sliding-mode, automatic gain modulation to eliminate hunting even with extreme gains. Axes will be perfectly still and have no loss of tracking or position accuracy.
- Teknic's proprietary Regressive AutoSpline™ (RAS) technology produces ultra-smooth trajectories. The profiles are jerk and jerk-derivative limited, which reduces shock, vibration, noise, and mechanical wear.

5000 Series Specifications

Servo Drive features: (continued)

- Many safety and protection features including: Short circuit (phase-to-phase, phase-to-ground), over temperature, over voltage, over current, protected for open windings, fuse, True RMS torque limiting, automatic speed limit, motor jam detection, and much more
- Superior tracking accuracy multi-derivative, state feed-forward gains greatly improve tracking performance and do not create the audible noise and torque chatter of traditional implementations

Teknic has been designing and building digital servo drives for nearly two decades. Tens of thousands of SSt drives are sent into the field each year to OEMs, with the first SSt having been delivered in 1994. With that field experience and an evolutionary approach, the SSt-U Series used by MultiCam is standing on the shoulders of the drives before it, which yields not only robust performance, but also MTBF numbers that make the competition blush. The MTBF of the SSt-1500, for example, is 730,609 hours.

Brushless AC Servo Motors

After extensive testing, MultiCam has found the MCG Brushless AC Servo Motors to be one of the best solutions on the market today. MCG has an extensive history in motors and controls dating back to its founding in 1961. With a long history of providing critical components to military and aerospace applications and a leading supplier to commercial and industrial applications, MCG create servo motors that give MultiCam machines a competitive edge in the market.

Brushless AC Servo Motor Features

- 100lb Radial Load 1" from front Face
- Brushless, maintenance-free sinewave servomotors With oversized, high precision, deep groove radial bearings being the only wear point
- Neodymium-Iron-Boron magnets providing high power density and fade-free performance
- High power-to-rotor inertia ratio



5000 Series Specifications

Brushless AC Servo Motor Features (continued)

- Direct winding on electrostatically powder-coated stators gives high thermal conductivity for better RMS ratings.
- Windings are rated to 135°C, improving thermal range.
- Low electrical time constants increase motor responsiveness, which improves tracking accuracy.
- Low distortion, sinusoidal back EMF combined with low detent torque improves motor smoothness and lowers audible noise.
- Precision bearings both reduce viscous friction and motor noise at high speed and help smooth motion. The high precision bearings are mechanically captivated and chemically bonded to maintain proper preload and alignment under all rated load conditions and accidental impacts.
- The stators are glued and mechanically locked to prevent slippage regardless of use conditions.
- Finite element analysis is utilized to reduce stress concentration on machined areas of the shaft. This allows the use of oversized bearings without sacrificing shaft strength.
- The encoder disk is a floating differential, and the read head has a multiple-aperture grating for reliable operation even when dusty or dirty. The read head is fully encapsulated for increased reliability and ruggedness. Combined with the triple redundant reading/voting circuits in the drive, this provides incredibly robust encoder capability.
- High Precision, floating mount differential encoder reduces cyclical run-out, which gives more repeatable positioning performance and makes the encoder resistant to high-speed shaft-impact damage.
- The 2000-line encoder with quadrature sampling produces 8000 counts per revolution.

5000 Series Specifications

High Speed Helical Rack System

The new High Speed Helical Rack system upgrade to the MultiCam 5000 Series CNC Router is very impressive. If watching the system move is not impressive enough, just wait until you cut with it.

The system comes standard with an automatic lubrication system that keeps a slight film of oil on the rack. The lubrication system is required to reliably achieve the velocity that the machine is capable of. With speeds of 2000 ipm single axis and 2800 maximum rapid traverse the Helical Rack System can get to a full speed move within 4.44 inches.

There are a number of advantages that Helical Rack has versus straight rack. Helical rack & pinions run much quieter than straight rack and pinions, especially at high speeds. Due to the angular cut in the Helical rack and pinion setup, there are thrust loads on the gear shaft. This action requires thrust bearings to absorb the load and maintain gear alignment. The Alpha Gear Boxes that MultiCam already uses are designed to handle this load, and the new design of the 5000 Series automated routers allow for exceptional perpendicularity and gear alignment. Faster acceleration and accuracy is achieved because of a greater number of teeth engaged than straight racks. Distributing the load over several teeth also reduces wear and increases the life of the rack and pinion system.

MultiCam recommends this upgrade to anyone that wants to cut smoother, faster, and more accurately. Cabinet shops or other companies that have projects requiring point to point drilling will see a substantial decrease in job times. This is primarily due to the high accelerations. Customers with longer machines will also see a significant benefit with the high-speed rapid traverse moves.



5000 Series Specifications

Standard Accessories



Leveling Feet



Tool Box



Operation Manual

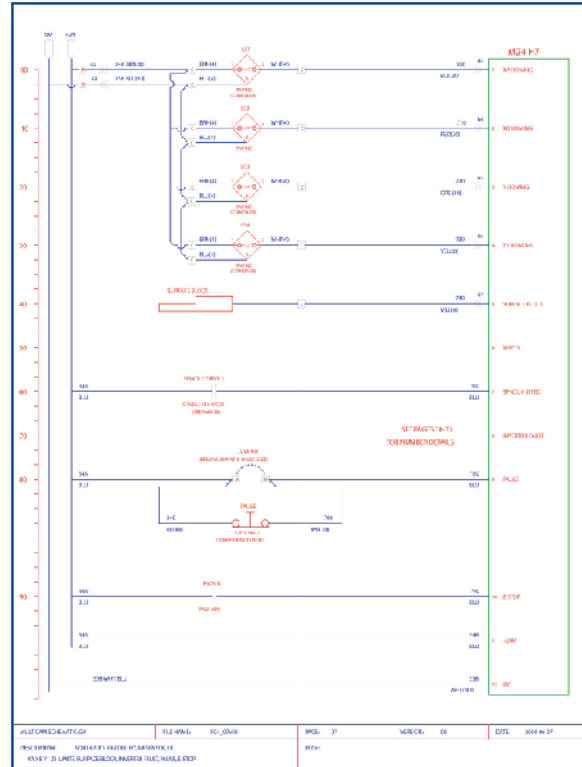

Electrical Schematics

inches

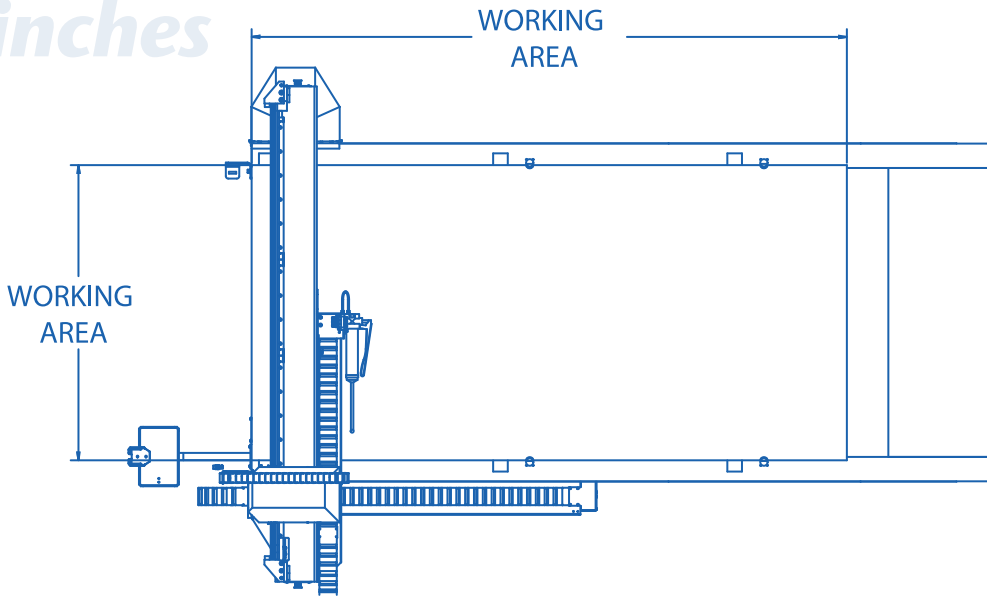

MultiCam

5000 Series

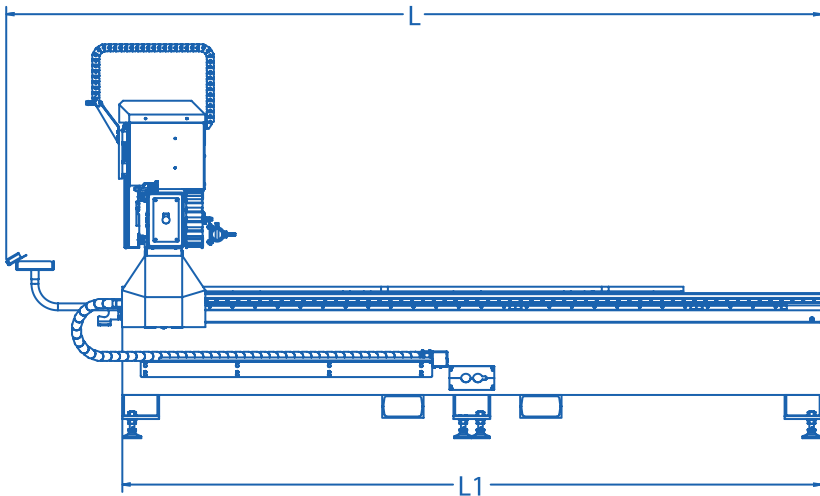

5000 Series Specs (inches)

- Z-Axis Clearance: 8" - Optional 12" or 16"
- Z-Axis Travel: 18"
- Repeatability: +/- .001"
- Positional Displacement Accuracy: +/- 0.005" over 10 feet
- Cutting Speed: 1,200 ipm
- Rapid Traverse: 2,200 ipm
- Drive System X and Y axis: Rack and Pinion
- Drive System Z axis: Ball Screw
- Standard Work Surface: 1" Phenolic

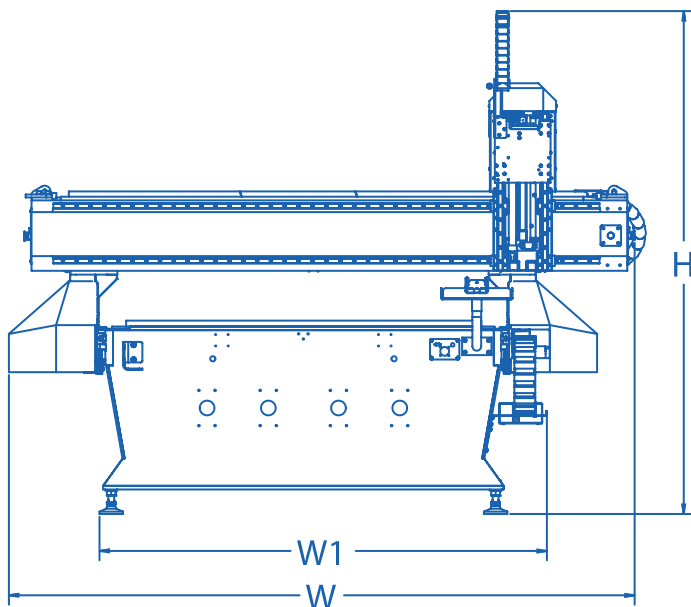

Size Chart (inches)

MODEL	L	L1	W	W1	H	WORKING AREA
101	108	76	89	66	86	50 x 50
103	158	126	89	66	86	50 x 100
202	118	86	99	76	86	60.5 x 60
204	184	152	99	76	86	60.5 x 122
205	202	170	99	76	86	60.5 x 145
208	300	268	99	76	86	60.5 x 242
304	184	152	119	96	86	80 x 122
305	202	170	119	96	86	80 x 145
308	300	268	119	96	86	80 x 242
404	184	152	135	112	86	96 x 122
405	202	170	135	112	86	96 x 145
408	300	268	135	112	86	96 x 242
505	202	170	159	136	86	120 x 145
508	300	268	159	136	86	120 x 242

Add 20 inches to W for optional Wide or Dual Carriages.
Add 4 inches to H for optional Wide Carriage.

metric

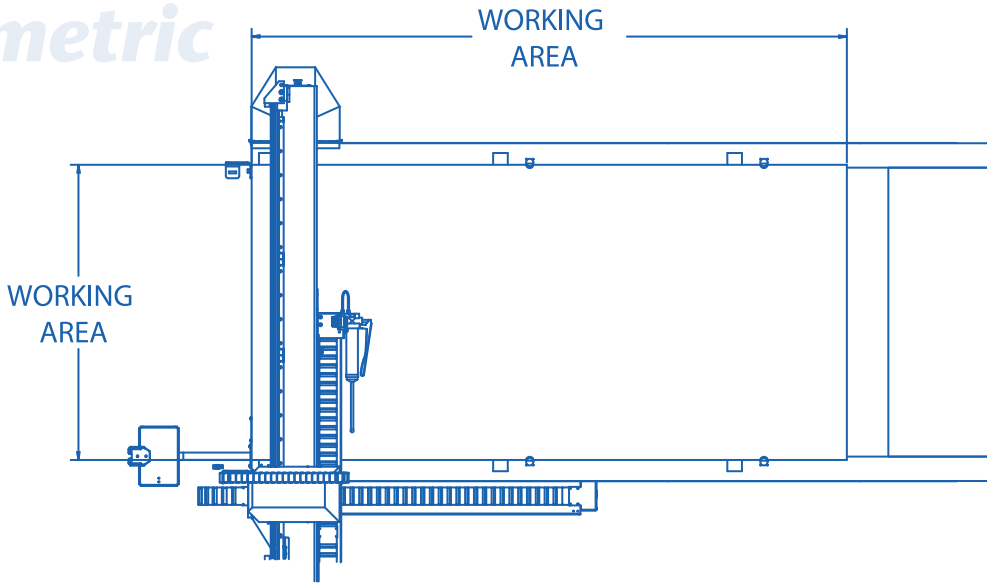

MultiCam

5000 Series

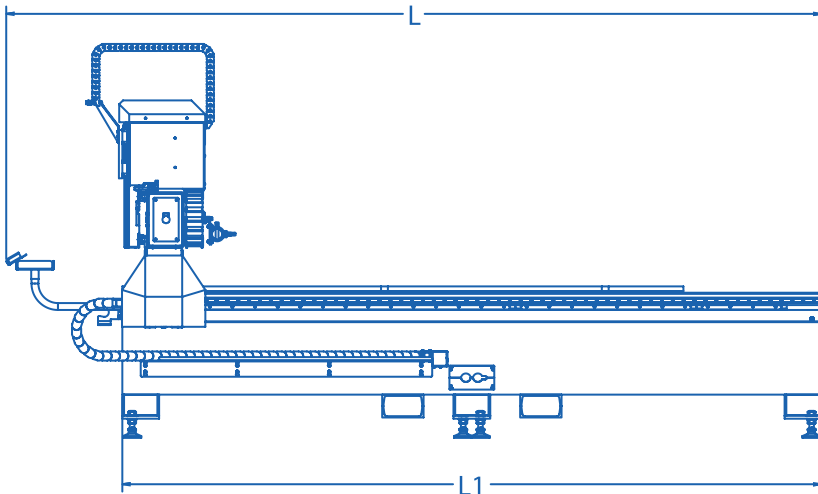

5000 Series Specs (metric)

- Z-Axis Clearance: 203 mm - Optional 304 mm or 406 mm
- Z-Axis Travel: 457 mm
- Repeatability: +/- .025 mm
- Positional Displacement Accuracy: +/- 0.125 mm over 3 meters
- Cutting Speed: 30.5 m/min (508 mm/sec)
- Rapid Traverse: 55.9 m/min (931 mm/sec)
- Drive System X and Y axis: Rack and Pinion
- Drive System Z axis: Ball Screw
- Standard Work Surface: 25 mm Phenolic

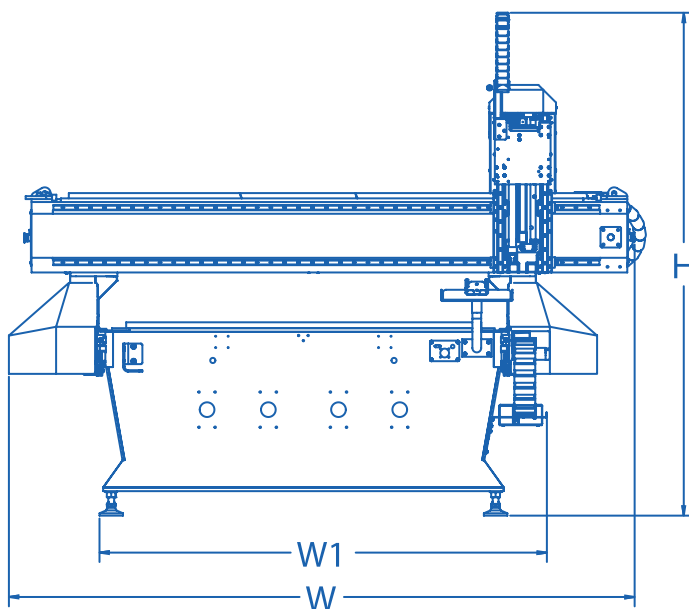

Size Chart (metric)

MODEL	L	L1	W	W1	H	WORKING AREA
101	2743	1930	2261	1676	2184	1270 x 1270
103	4013	3200	2261	1676	2184	1270 x 2540
202	2997	2184	2515	1930	2184	1537 x 1524
204	4674	3861	2515	1930	2184	1537 x 3099
205	5131	4318	2515	1930	2184	1537 x 3683
208	7620	6807	2515	1930	2184	1537 x 6147
304	4674	3861	3023	2438	2184	2032 x 3099
305	5131	4318	3023	2438	2184	2032 x 3683
308	7620	6807	3023	2438	2184	2032 x 6147
404	4674	3861	3429	2845	2184	2438 x 3099
405	5131	4318	3429	2845	2184	2438 x 3683
408	7620	6807	3429	2845	2184	2438 x 6147
505	5131	4318	4039	3454	2184	3048 x 3683
508	7620	6807	4039	3454	2184	3048 x 6147

Add 508 mm to W for optional Wide or Dual Carriages.
Add 102 mm to H for optional Wide Carriage.